

# Synthesis of phosphinochalcogenoic amidato complexes of divalent transition metals and their thermolysis to metal selenide and telluride phases †

Xuejing Song and Manfred Bochmann\*

School of Chemistry, University of Leeds, Leeds, UK LS2 9JT

Protolysis of the transition-metal diamides  $[M\{N(\text{SiMe}_3)_2\}_2(\text{thf})_n]$  ( $M = \text{Cr, Mn, Fe or Co}$ ) with 2 equivalents of phosphinochalcogenoic amides  $\text{Bu}^t_2\text{P}(\text{E})\text{NHR}$  ( $\text{E} = \text{Se or Te, R} = \text{Pr}^i \text{ or cyclo-C}_6\text{H}_{11}$ ) gave a series of thermally stable metal–selenium and –tellurium complexes  $[M\{\text{Bu}^t_2\text{P}(\text{E})\text{NR}\}_2]$ . The complex  $[\text{Ni}\{\text{Bu}^t_2\text{P}(\text{Se})\text{NR}\}_2]$  was obtained from  $\text{Li}[\text{Bu}^t_2(\text{Se})\text{NR}]$  and  $[\text{NiCl}_2(\text{PMe}_3)_2]$ . The compounds sublime readily under reduced pressure and are suitable for the gas-phase deposition of metal chalcogenide films. The selenium precursors lead to  $\text{MSe}$  ( $M = \text{Cr, Mn, Fe or Ni}$ ), while tellurium complexes afford  $\text{MTe}_2$  ( $M = \text{Fe, Mn or Co}$ ). By contrast,  $[\text{Co}\{\text{Bu}^t_2\text{P}(\text{Se})\text{NR}\}_2]$  gives  $\text{Co}_3\text{Se}_4$ , while  $[\text{Ni}\{\text{Bu}^t_2\text{P}(\text{Se})\text{NR}\}_2]$  generates  $\text{NiSe}$  or  $\text{Ni}_6\text{Se}_5$ , depending on the deposition conditions.

Phosphinochalcogenoic amidato anions  $[\text{R}_2\text{P}(\text{E})\text{NR}']^-$  ( $\text{E} = \text{O or Se}$ ) are known to give stable chelate complexes with a variety of metals.<sup>1</sup> For example, the sulfur compounds form a series of monomeric complexes of  $\text{Co}^{\text{II}}$  and  $\text{Ni}^{\text{II}}$ ,  $[M\{\text{R}_2\text{P}(\text{S})\text{NR}'\}_2]$ , with square-planar or tetrahedral structures, depending on the size of  $\text{R}$  and  $\text{R}'$ .<sup>2</sup> We have recently prepared related phosphino-selenoic and -telluroic amides<sup>3</sup> and shown that the zinc and cadmium complexes  $[M\{\text{Bu}^t_2\text{P}(\text{E})\text{NR}\}_2]$  ( $M = \text{Zn, or Cd, E} = \text{Se or Te}$ )<sup>4</sup> are very suitable as precursors for the deposition of  $\text{ME}$  films by low-pressure MOCVD (metal-organic chemical vapour deposition) methods.<sup>5</sup> Single-source precursors for metal chalcogenide materials have attracted considerable interest.<sup>6</sup> Those suitable for the gas-phase deposition of films must be sufficiently volatile and combine the right degree of thermal stability with the ability to decompose cleanly at moderate temperatures, preferably between 200 and 400 °C. The thermal stability of the tellurium derivatives described here is particularly noteworthy in this context since few tellurium complexes possess the properties required for gas-phase deposition processes. For example, a number of complexes of  $\text{Cr, Mn, Fe}$  and  $\text{Co}$  with the silyltelluroato ligand  $[\text{TeSi}(\text{SiMe}_3)_3]^-$  have been reported. Contrary to expectation, none of these proved sufficiently volatile and stable to allow sublimation under reduced pressure and metal telluride film growth.<sup>7</sup>

Various approaches have recently been explored to generate transition-metal chalcogenides by the thermolysis of well defined precursor complexes, usually in solution or in the solid state. For example, heating dithiocarbamate complexes of  $\text{Fe}^{\text{II}}$ ,  $\text{Ni}^{\text{II}}$  and  $\text{Co}^{\text{II}}$  leads to a number of metal sulfide phases, depending on the reaction conditions.<sup>8</sup> The thermolysis of  $[\text{Mn}(\text{CO})_3(\text{PEt}_3)_2(\text{TeCH}_2\text{Ph})]$ <sup>9</sup> or of the ditelluride  $[\{(\text{Et}_3\text{P})_2(\text{OC})_3\text{MnTe}\}_2]$ <sup>10</sup> at 300 °C leaves a residue of polycrystalline  $\text{MnTe}$ , and the sealed-tube pyrolysis of the iron telluride complexes  $[\{\text{Fe}(\text{cp})(\text{CO})(\text{PEt}_3)_2\}_2\text{Te}]$  ( $\text{cp} = \eta\text{-C}_5\text{H}_5$ ) and  $[\text{Fe}_4\text{Te}_4(\text{PEt}_3)_4]$  gives  $\text{FeTe}$  powders.<sup>11</sup> Manganese selenide and telluride are important because of their optoelectronic properties and as magnetic dopants for Group II–VI semiconductors.<sup>12</sup> We report here the synthesis of a series of selenium and tellurium complexes of the type  $[M\{\text{Bu}^t_2\text{P}(\text{E})\text{NR}\}_2]$  and their behaviour as precursors for the gas-phase deposition of metal chalcogenide films.

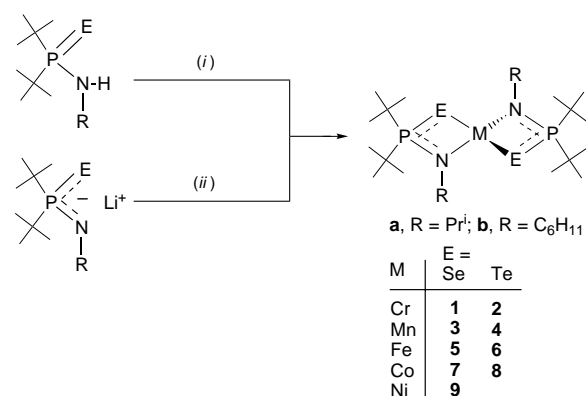

**Scheme 1** (i)  $[M\{N(\text{SiMe}_3)_2\}_2]$ , light petroleum, room temperature (r.t.); (ii)  $\text{CrCl}_2$ ,  $\text{FeCl}_2$  or  $[\text{NiCl}_2(\text{PMe}_3)_2]$ , thf, r.t.

## Results and Discussion

The reaction of a series of bis(amido) complexes of divalent transition metals  $[M\{N(\text{SiMe}_3)_2\}_2(\text{thf})_n]$  ( $M = \text{Cr, Mn, Fe or Co}$ ; thf = tetrahydrofuran) with the di-*tert*-butylphosphinochalcogenoic amides  $\text{Bu}^t_2\text{P}(\text{E})\text{NHR}$  ( $\text{E} = \text{Se or Te}$ ) in light petroleum at room temperature leads to the isolation of the corresponding complexes  $[M\{\text{Bu}^t_2\text{P}(\text{E})\text{NR}\}_2]$  **1–9** in high yields ( $\text{R} = \text{Pr}^i$  **a** or cyclo- $\text{C}_6\text{H}_{11}$  **b**) (Scheme 1). All complexes are moderately soluble in light petroleum but are isolated by recrystallisation from toluene as well shaped crystals. The chromium and iron complexes **1a** and **5a** were also made from the reaction of  $\text{Li}[\text{Bu}^t_2\text{P}(\text{Se})\text{NPr}^i]$  with  $\text{MCl}_2$  in thf, while the nickel derivatives **9a** and **9b** were obtained from  $\text{Li}[\text{Bu}^t_2\text{P}(\text{Se})\text{NR}]$  and  $[\text{NiCl}_2(\text{PMe}_3)_2]$ . Attempts to isolate the analogous nickel–tellurium complexes failed, however; these compounds appear to be thermally unstable. The analytical data of the new complexes are collected in Table 1.

Numerous attempts were made to grow X-ray-quality crystals. Unfortunately all samples proved to be twinned. Mass spectrometric data, the solubility behaviour and the volatility of these compounds suggest, however, that like the sulfur complexes  $[M\{\text{Bu}^t_2\text{P}(\text{S})\text{NR}\}_2]$  ( $M = \text{Co or Ni}$ )<sup>2a</sup> all these complexes are monomeric, with a distorted tetrahedral structure, analogous to the structurally characterised zinc complex  $[\text{Zn}\{\text{Bu}^t_2\text{P}(\text{Se})\text{NPr}^i\}_2]$ .<sup>4</sup>

† Non-SI units employed: bar = 101 325 Pa,  $\mu_{\text{B}} \approx 9.27 \times 10^{-24} \text{ J T}^{-1}$ .

**Table 1** Analytical data of phosphinochalcogenoic amido complexes

Compound	Colour	Yield (%)	M.p./°C	$\mu/\mu_B$	Analysis (%) <sup>a</sup>		
					C	H	N
<b>1a</b> [Cr{Bu <sup>t</sup> <sub>2</sub> P(Se)NPr <sup>i</sup> ] <sub>2</sub> ]	Light blue	36	>220 <sup>b</sup>		42.6 (43.0)	8.2 (8.1)	4.6 (4.6)
<b>1b</b> [Cr{Bu <sup>t</sup> <sub>2</sub> P(Se)NC <sub>6</sub> H <sub>11</sub> ] <sub>2</sub> ]	Light blue	41	>220 <sup>b</sup>		48.2 (48.4)	8.2 (8.4)	3.9 (4.0)
<b>2a</b> [Cr{Bu <sup>t</sup> <sub>2</sub> P(Te)NPr <sup>i</sup> ] <sub>2</sub> ]	Light green	75	228 <sup>b</sup>		42.7 (42.5)	7.1 (7.3)	3.4 (3.5)
<b>2b</b> [Cr{Bu <sup>t</sup> <sub>2</sub> P(Te)NC <sub>6</sub> H <sub>11</sub> ] <sub>2</sub> ]	Light turquoise	57	>115 <sup>b</sup>		36.7 (37.1)	7.0 (7.0)	3.8 (3.9)
<b>3a</b> [Mn{Bu <sup>t</sup> <sub>2</sub> P(Se)NPr <sup>i</sup> ] <sub>2</sub> ]	White	79	220		42.9 (42.8)	7.8 (8.1)	4.9 (4.5)
<b>3b</b> [Mn{Bu <sup>t</sup> <sub>2</sub> P(Se)NC <sub>6</sub> H <sub>11</sub> ] <sub>2</sub> ]	White	74	>220	5.8	48.8 (48.2)	8.5 (8.5)	3.8 (4.0)
<b>4a</b> [Mn{Bu <sup>t</sup> <sub>2</sub> P(Te)NPr <sup>i</sup> ] <sub>2</sub> ]	Off-white	70	>230 <sup>b</sup>		37.0 (37.0)	6.9 (7.0)	4.2 (3.9)
<b>4b</b> [Mn{Bu <sup>t</sup> <sub>2</sub> P(Te)NC <sub>6</sub> H <sub>11</sub> ] <sub>2</sub> ]	Off-white	76	>230 <sup>b</sup>		42.4 (42.3)	7.3 (7.3)	3.3 (3.5)
<b>5a</b> [Fe{Bu <sup>t</sup> <sub>2</sub> P(Se)NPr <sup>i</sup> ] <sub>2</sub> ]	White	65	>220		43.4 (42.7)	8.5 (8.1)	4.2 (4.5)
<b>5b</b> [Fe{Bu <sup>t</sup> <sub>2</sub> P(Se)NC <sub>6</sub> H <sub>11</sub> ] <sub>2</sub> ]	White	46	>220	5.0	48.4 (48.2)	8.3 (8.3)	3.8 (4.0)
<b>6a</b> [Fe{Bu <sup>t</sup> <sub>2</sub> P(Te)NPr <sup>i</sup> ] <sub>2</sub> ]	Yellow	67	206		36.9 (36.9)	6.9 (7.0)	3.7 (3.9)
<b>6b</b> [Fe{Bu <sup>t</sup> <sub>2</sub> P(Te)NC <sub>6</sub> H <sub>11</sub> ] <sub>2</sub> ]	Yellow	67	>220		42.5 (42.3)	7.4 (7.3)	3.5 (3.5)
<b>7a</b> [Co{Bu <sup>t</sup> <sub>2</sub> P(Se)NPr <sup>i</sup> ] <sub>2</sub> ]	Violet	89	240	4.8	42.6 (42.5)	7.9 (8.0)	4.2 (4.0)
<b>7b</b> [Co{Bu <sup>t</sup> <sub>2</sub> P(Se)NC <sub>6</sub> H <sub>11</sub> ] <sub>2</sub> ]	Violet-blue	91	>220	5.4	48.0 (47.9)	8.2 (8.3)	3.8 (4.0)
<b>8a</b> [Co{Bu <sup>t</sup> <sub>2</sub> P(Te)NPr <sup>i</sup> ] <sub>2</sub> ]	Dark green	86	236 <sup>b</sup>		36.9 (36.8)	6.8 (7.0)	3.7 (3.9)
<b>8b</b> [Co{Bu <sup>t</sup> <sub>2</sub> P(Te)NC <sub>6</sub> H <sub>11</sub> ] <sub>2</sub> ]	Dark green	45	220	5.0	42.4 (42.1)	7.1 (7.3)	3.4 (3.5)
<b>9a</b> [Ni{Bu <sup>t</sup> <sub>2</sub> P(Se)NPr <sup>i</sup> ] <sub>2</sub> ]	Green	43	224 <sup>b</sup>	3.0	42.6 (42.5)	8.1 (8.1)	4.3 (4.5)
<b>9b</b> [Ni{Bu <sup>t</sup> <sub>2</sub> P(Se)NC <sub>6</sub> H <sub>11</sub> ] <sub>2</sub> ]	Green	50	>260	3.0	48.2 (48.0)	8.4 (8.3)	3.9 (4.0)

<sup>a</sup> Calculated values in parentheses. <sup>b</sup> With decomposition.

**Table 2** Formation of metal chalcogenide films by gas-phase thermolysis of [M{Bu<sup>t</sup><sub>2</sub>P(E)NR'}<sub>2</sub>] complexes<sup>a</sup>

Compound	T/°C			Metal chalcogenide phase	JCPDS reference <sup>b</sup>
	Reactor	Substrate	t/min		
<b>1a</b>	210	400	40	Cr <sub>0.68</sub> Se <sup>c</sup>	21-0241
<b>1b</b>	200–220	380–420	30	Cr <sub>0.68</sub> Se <sup>c</sup>	
<b>3a</b>	190–220	370–450	120–240	$\alpha$ -MnSe (cubic) <sup>c</sup>	11-683
<b>3b</b>	190–220	340–460	60–180	$\alpha$ -MnSe	
<b>4a</b>	170	380	60	MnTe <sub>2</sub> (cubic)	18-813
	220	350	120	MnTe <sub>2</sub>	
<b>4b</b>	200	350	120	MnTe <sub>2</sub>	18-813
<b>5a, 5b</b>	200–210	400–420	20–50	FeSe (hexagonal) <sup>c</sup>	26-795
<b>6a, 6b</b>	170–180	400	20	FeTe <sub>2</sub> <sup>c</sup>	14-0419
<b>7a</b>	150	400	120	Co <sub>3</sub> Se <sub>4</sub>	15-0463
	170	400	15	Co <sub>3</sub> Se <sub>4</sub> (+CoSe <sub>2</sub> )	(9-234)
<b>7b</b>	180	320	60	Co <sub>3</sub> Se <sub>4</sub>	15-0463
	200	350	30	Co <sub>3</sub> Se <sub>4</sub>	
<b>8a</b>	150–200	320–350	120	CoTe <sub>2</sub> <sup>c</sup> (orthorhombic)	11-553
<b>8b</b>	180	320–350	60	CoTe <sub>2</sub>	
<b>9a</b>	210	300	10	Ni <sub>6</sub> Se <sub>5</sub>	29-0934
	210	270	15	Ni <sub>6</sub> Se <sub>5</sub>	29-0934
	220	300	60	NiSe	02-0892
<b>9b</b>	210	260	25	Ni <sub>6</sub> Se <sub>5</sub>	29-0934
	200	400	10	NiSe + NiSe <sub>2</sub>	02-0892/41-1495

<sup>a</sup> Reactor pressure (1.6–5.4) × 10<sup>-6</sup> mbar. <sup>b</sup> Joint Committee on Powder Diffraction Standards, International Center of Diffraction Data, Swarthmore, PA. <sup>c</sup> Film with strong preferential orientation. MnSe, [200]; FeTe<sub>2</sub>, [011]; CoTe<sub>2</sub>, [120].

The magnetic moments indicate high-spin configurations in the solid state. As Kuchen and co-workers<sup>2</sup> showed, the magnetism of the nickel complexes [Ni{R<sub>2</sub>P(S)NR'}<sub>2</sub>] can be very variable, and diamagnetic as well as paramagnetic complexes are known. The nickel complexes **9a** and **9b** closely resemble in this respect the sulfur analogues with R = Bu<sup>t</sup> and R' = Pr<sup>i</sup> or cyclo-C<sub>6</sub>H<sub>11</sub>.<sup>2a</sup>

The driving force for the preparation of these complexes was to explore their potential as single-source precursors for the gas-phase deposition of metal chalcogenide films, particularly for metal tellurides for which sufficiently volatile and thermally stable precursor complexes were, until now, rare or non-existent. The phosphinochalcogenoic amidato complexes described here fulfil these requirements and have proved superior to bulky arene chalcogenolato complexes.<sup>13,14</sup> All new complexes (with the exception of **2a** and **2b**) sublime under reduced pressure between 150 and 220 °C and deposit metal chalcogenide films on glass substrates heated to 320–400 °C. There was little difference in the volatility of the isopropyl (**a**) and cyclohexyl (**b**) derivatives, although the latter appeared

thermally slightly more stable. The results are shown in Table 2. The solid state products were assigned by their X-ray diffraction patterns in comparison with the Joint Committee on Powder Diffraction Standards (JCPDS) data of authentic samples. As is common for gas-phase deposited films, the metal chalcogenide products showed strong preferential orientation in almost all cases.

In contrast to the thermolysis of the zinc and cadmium phosphinochalcogenoic amidato complexes described earlier, which leads exclusively to films with a 1:1 metal:chalcogenide ratio, transition-metal chalcogenides can form a large number of compounds with different M:E stoichiometries and different metal oxidation states. In general, selenium precursors give films with lower chalcogenide:metal ratios than does tellurium. For example, **3a** and **3b** give strongly oriented films of cubic  $\alpha$ -MnSe (rock salt structure, *a* = 5.462 Å), while **5a** and **5b** generate hexagonal FeSe (achavalite-type). The behaviour of the cobalt complexes **7a** and **7b** is more complex; they generally lead to mixtures of Co<sub>3</sub>Se<sub>4</sub> together with CoSe<sub>2</sub> as a minor component, although for shorter reaction times (30 min) and

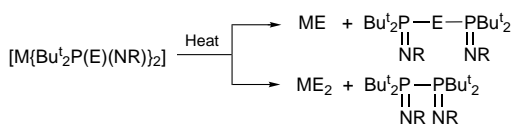

Scheme 2

lower reactor and substrate temperatures (180 and 320 °C, respectively) only Co<sub>3</sub>Se<sub>4</sub> could be detected. By contrast, the bulk pyrolysis of the selenide cluster [Co<sub>6</sub>Se<sub>8</sub>(PET<sub>3</sub>)<sub>6</sub>] above 325 °C is reported to give μ-CoSe.<sup>15</sup> On the other hand, selenidation of cobalt foil at 550–700 °C has been reported to give Co<sub>3</sub>Se<sub>4</sub> films with a thin surface layer of CoSe<sub>2</sub>.<sup>16</sup>

The decomposition of complexes **9a** and **9b** depended to some extent on the reaction conditions. At thermolysis temperatures of 260–300 °C Ni<sub>6</sub>Se<sub>5</sub> was formed, while at ≥300 °C NiSe was produced, sometimes as a mixture with some NiSe<sub>2</sub>. The chromium complexes **1a** and **1b** gave films which showed an X-ray diffraction pattern very close to that of Cr<sub>0.68</sub>Se.

The thermolysis of the tellurium complexes **4**, **6** and **8** proceeded more straightforwardly to give films of the metal ditellurides MTe<sub>2</sub> (M = Mn, Fe or Co). The chromium complexes **2a** and **2b** decompose appreciably above 115 °C, before an adequate sublimation rate could be reached, and attempts at growing chromium telluride films proved unsuccessful. All the metal chalcogenide films were checked by energy-dispersive X-ray fluorescence (EDAX) analysis for trace impurities. There was no evidence for phosphorus incorporation within the detection limits of this technique.

The deposition of MnTe<sub>2</sub> films from complex **4** contrasts with the formation of MnTe from the bulk pyrolysis of precursors such as [(Et<sub>3</sub>P)<sub>2</sub>(CO)<sub>3</sub>MnTe]<sub>2</sub> for which no MnTe<sub>2</sub> was detected.<sup>10</sup> Formation of MTe<sub>2</sub> phases is expected on the basis of the M:Te stoichiometry, at least at lower reaction temperatures where the rate of tellurium loss due to evaporation is limited. The stoichiometries of iron tellurides were found previously to depend on the Fe:Te ratio of the precursor, with [(Fe(cp)(CO)(PET<sub>3</sub>)<sub>2</sub>)Te] (Fe:Te = 2:1) leading to FeTe, while [(Et<sub>3</sub>P)(OC)(cp)FeTe]<sub>2</sub> (Fe:Te = 1:1) resulted in FeTe<sub>2</sub>.<sup>11a</sup> On the other hand, another precursor with a 1:1 Fe:Te ratio, [Fe<sub>4</sub>Te<sub>4</sub>(PET<sub>3</sub>)<sub>4</sub>], generates FeTe.<sup>11b</sup> Both FeTe and FeTe<sub>2</sub> are of interest, for example, as catalysts for the oxychlorination of propene.<sup>17</sup>

There are numerous phases Co<sub>1-x</sub>Te. Steigerweld *et al.*<sup>18</sup> showed that the telluride cluster [Co<sub>6</sub>Te<sub>8</sub>(PET<sub>3</sub>)<sub>6</sub>] is thermolysed at 300 °C to give β-CoTe. This contrasts with the formation of orthorhombic CoTe<sub>2</sub> from complex **8** at similar temperatures but under reduced pressure.

The thermolysis reactions of complexes **1–9** to give mono- or di-chalcogenide solid-state products can in a simplified manner be described as shown in Scheme 2, *i.e.* leading to selenium-containing by-products where metal monoselenides are formed, while the deposition of MTe<sub>2</sub> phases results in tellurium-free organic residues. The organic by-products of the thermolysis reactions were monitored by mass spectrometry and <sup>31</sup>P NMR spectroscopy. The deposition of metal selenides was accompanied by a product mixture which was identified mainly as Bu<sup>t</sup><sub>2</sub>P(Se)NHR. Similar thermolysis fragments had previously been identified as by-products of the growth of zinc and cadmium chalcogenide films.<sup>5</sup> By contrast, the deposition of MTe<sub>2</sub> phases gave rise to tellurium-free products such as (Bu<sup>t</sup><sub>2</sub>P)<sub>2</sub>NH<sup>+</sup> (*m/z* 305).

The results show that sterically hindered phosphinochalcogenoic amides are highly suitable ligands for the synthesis of a series of transition-metal selenium and thermally comparatively stable tellurium complexes which, due to their monomeric structure and volatility, are suitable as precursors for the gas-phase deposition of ordered transition-metal selenide and telluride films.

## Experimental

### General procedures

All reactions were carried out under dry nitrogen using standard vacuum-line techniques. Solvents were distilled under nitrogen from sodium–benzophenone [diethyl ether, thf, light petroleum (b.p. 40–60 °C)], sodium (toluene) or calcium hydride (dichloromethane). Magnetic moments were measured on powdered samples under nitrogen, using a Johnson-Matthey magnetic balance. Powder X-ray diffraction data were recorded using a Phillips PW 1710 diffractometer. The compounds [Cr{N(SiMe<sub>3</sub>)<sub>2</sub>}(thf)<sub>2</sub>],<sup>19</sup> [Mn{N(SiMe<sub>3</sub>)<sub>2</sub>}(thf)<sub>2</sub>],<sup>20</sup> [Fe{N(SiMe<sub>3</sub>)<sub>2</sub>}]<sub>2</sub>,<sup>21</sup> [Co{N(SiMe<sub>3</sub>)<sub>2</sub>}(thf)]<sub>2</sub>,<sup>22</sup> Bu<sup>t</sup><sub>2</sub>P(E)NHR (E = Se or Te, R = Pr<sup>i</sup> or cyclo-C<sub>6</sub>H<sub>11</sub>)<sup>3</sup> were prepared according to literature methods.

### Preparation of complexes

Most complexes were prepared from the metal amides following closely similar procedures. Alternatively, metathesis of MCl<sub>2</sub> with Li[Bu<sup>t</sup><sub>2</sub>P(E)NR] can be used in some cases, although yields tend to be lower. Representative methods are given below.

**Method A, [Cr{Bu<sup>t</sup><sub>2</sub>P(Te)NC<sub>6</sub>H<sub>11</sub>}]<sub>2</sub> **2b**.** To a solution of [Cr{N(SiMe<sub>3</sub>)<sub>2</sub>}(thf)<sub>2</sub>] (1.60 g, 3.10 mmol) in light petroleum (15 cm<sup>3</sup>) at room temperature was added Bu<sup>t</sup><sub>2</sub>P(Te)NHC<sub>6</sub>H<sub>11</sub> (2.30 g, 6.20 mmol) in light petroleum (15 cm<sup>3</sup>). The dark mixture was stirred for 3 h. A precipitate formed which was filtered off and recrystallised from toluene to afford light turquoise crystals of complex **2b** (1.40 g, 57%).

The compounds **2**, **3**, **4**, **6**, **7** and **8** were obtained similarly.

**Method B, [Cr{Bu<sup>t</sup><sub>2</sub>P(Se)NPr<sup>i</sup>}]<sub>2</sub> **1a**.** A solution of Bu<sup>t</sup><sub>2</sub>P(Se)NHPPr<sup>i</sup> (2.54 g, 9.0 mmol) in thf (100 cm<sup>3</sup>) was treated with a 2.5 M solution (3.6 cm<sup>3</sup>) of LiBu<sup>n</sup> (9.0 mmol) in hexanes at 0 °C. The yellow solution formed was allowed to warm to room temperature and stirred for 1 h. To this was added CrCl<sub>2</sub> (0.55 g, 4.5 mmol) in thf (20 cm<sup>3</sup>). The reaction mixture was stirred for 4 h. After evaporation of the solvent *in vacuo* the residue was extracted with toluene to give light blue crystals of complex **1a** (1.0 g, 36%).

The compounds **1b**, **5a** and **5b** were prepared similarly. The iron–tellurium complexes **6a** and **6b** can however only be obtained using method A.

**Method C, [Ni{Bu<sup>t</sup><sub>2</sub>P(Se)NPr<sup>i</sup>}]<sub>2</sub> **9a**.** A solution of Bu<sup>t</sup><sub>2</sub>P(Se)NHPPr<sup>i</sup> (2.55 g, 9.0 mmol) in thf (100 cm<sup>3</sup>) was treated with LiBu<sup>n</sup> (2.5 M, 3.6 cm<sup>3</sup>, 9.0 mmol) in hexanes at 0 °C and allowed to warm to room temperature. To this was added a solution of [NiCl<sub>2</sub>(PMe<sub>3</sub>)<sub>2</sub>] (1.26 g, 4.5 mmol) in thf (20 cm<sup>3</sup>) at room temperature. The dark green solution was stirred for 4 h, the solvent was removed *in vacuo*, and the residue extracted with toluene. Cooling of the filtrate to –16 °C gave green crystals of complex **9a** (1.20 g, 43%).

Compound **9b** was obtained similarly. No nickel products could be isolated using Li[Bu<sup>t</sup><sub>2</sub>P(Te)NR].

### Thermolysis reactions

Gas-phase depositions of metal chalcogenide films were carried out in a horizontal reactor described earlier,<sup>14</sup> evacuated to *ca.* 2 × 10<sup>–6</sup> mbar. Glass substrates were degreased in boiling trichloroethane, cleaned by a H<sub>2</sub>O<sub>2</sub>/H<sub>2</sub>SO<sub>4</sub> treatment and washed repeatedly with deionised water. Films were grown by placing the precursor complex (*ca.* 50 mg) in a glass boat inside the all-glass reactor which was evacuated to *ca.* (1–6) × 10<sup>–6</sup> mbar and heated in a thermostatted oven to the given sublimation temperature of 170–230 ± 1 °C (*cf.* Table 2), while the glass substrate was mounted on a hot-finger and kept at a higher deposition temperature. Highly oriented specular polycrystal-

line films were obtained, typically of 1–1.5  $\mu\text{m}$  thickness after a growth period of 1–2 h. The phases were identified by their X-ray patterns using either Co-K $\alpha$  ( $\lambda = 1.7902 \text{ \AA}$ ) or Cu-K $\alpha$  ( $\lambda = 1.542 \text{ \AA}$ ) radiation; either X-ray source showed the films to be strongly oriented. The elemental composition and the absence of phosphorus impurities was confirmed by EDAX analysis (typical detection limit ca. 0.01% w/w).

## Acknowledgements

This work was supported by the Engineering and Physical Sciences Research Council. We are grateful to Mr S. Bennett, University of East Anglia, for powder X-ray and EDAX measurements.

## References

- 1 E. Lindner and H. M. Ebinger, *Chem. Ber.*, 1974, **107**, 448; M. Fuchs, W. Kuchen and W. Peters, *Chem. Ber.*, 1986, **119**, 1569; N. Kuhn, A. Kuhn and P. Sartori, *Chem.-Ztg.*, 1988, **112**, 251; M. Fuchs, W. Kuchen and W. Peters, *Z. Anorg. Allg. Chem.*, 1987, **545**, 75.
- 2 (a) A. Deeg, W. Kuchen, D. Langsch, D. Mootz, W. Peters and H. Wunderlich, *Z. Anorg. Allg. Chem.*, 1991, **606**, 119; (b) T. Frömmel, W. Peters, H. Wunderlich and W. Kuchen, *Angew. Chem., Int. Ed. Engl.*, 1992, **31**, 612; 1993, **32**, 907.
- 3 M. Bochmann, G. C. Bwembya, N. Whilton, X. Song, M. B. Hursthouse, S. J. Coles and A. Karaulov, *J. Chem. Soc., Dalton Trans.*, 1995, 1887.
- 4 M. Bochmann, G. C. Bwembya, M. B. Hursthouse and S. J. Coles, *J. Chem. Soc., Dalton Trans.*, 1995, 2815.
- 5 G. C. Bwembya, X. Song and M. Bochmann, *Chem. Vap. Deposition*, 1995, **1**, 78.
- 6 M. Bochmann, *Chem. Vap. Deposition*, 1996, **2**, 85; P. O'Brien, M. A. Malik, M. Chunggaze, T. Trindade, J. R. Walsh and A. C. Jones, *J. Cryst. Growth*, 1997, **170**, 23; see also, P. O'Brien and T. Trindade, *Adv. Mater.*, 1996, **8**, 161; *J. Mater. Chem.*, 1996, **6**, 343; P. O'Brien, J. R. Walsh, I. M. Watson, M. Motevalli and L. Henriksen, *J. Chem. Soc., Dalton Trans.*, 1996, 2491.
- 7 D. E. Grindelberger and J. Arnold, *Inorg. Chem.*, 1993, **32**, 5813.
- 8 H. Cui, R. D. Pike, R. Kershaw, K. Dwight and A. Wold, *J. Solid State Chem.*, 1992, **101**, 115; G. H. Singhal, R. I. Botto, L. D. Brown and K. S. Colle, *J. Solid State Chem.*, 1994, **109**, 166.
- 9 A. P. Coleman, R. S. Dickson, G. B. Deacon, G. D. Fallon, M. Ke, K. McGregor and B. O. West, *Polyhedron*, 1994, **13**, 1277.
- 10 M. L. Steigerwald and C. E. Rice, *J. Am. Chem. Soc.*, 1988, **110**, 4228.
- 11 (a) M. L. Steigerwald, *Chem. Mater.*, 1989, **1**, 52; (b) M. L. Steigerwald, T. Siegrist and S. M. Stuczynski, *Chem. Mater.*, 1992, **114**, 3155.
- 12 See, for example, W. Heimbrodt, L. Gridnera, M. Happ, F. Neugebauer, D. Suisky, N. Hoffmann and J. Griesche, *J. Cryst. Growth*, 1996, **159**, 1005; R. H. Mauch and K. O. Velthaus, *Ger. Pat.*, DE 4 435 016 (*Chem. Abstr.*, 1996, **124**, 30 1976u); V. Nunez, T. M. Giebultowicz, W. Faschinger, G. Bauer, H. Sitter and J. K. Furdyna, *Mater. Res. Soc. Symp. Proc.*, 1995, **376**, 589; J. M. Hartmann, G. Feuillet, M. Charleux and H. Mariette, *J. Appl. Phys.*, 1996, **79**, 3035.
- 13 M. Bochmann, K. Webb, M. Harman and M. B. Hursthouse, *Angew. Chem., Int. Ed. Engl.*, 1990, **29**, 638; M. Bochmann and K. J. Webb, *Mater. Res. Soc. Symp. Proc.*, 1991, **204**, 149; M. Bochmann, A. P. Coleman, K. J. Webb, M. B. Hursthouse and M. Mazid, *Angew. Chem., Int. Ed. Engl.*, 1991, **30**, 973; M. Bochmann, A. K. Powell and X. Song, *J. Chem. Soc., Dalton Trans.*, 1995, 1645; M. Bochmann, X. Song, M. B. Hursthouse and A. Karaulov, *J. Chem. Soc., Dalton Trans.*, 1995, 1649; M. Bochmann, G. C. Bwembya, A. K. Powell and X. Song, *Polyhedron*, 1995, **14**, 3495.
- 14 M. Bochmann, K. J. Webb, J. E. Hails and D. Wolverson, *Eur. J. Solid State Inorg. Chem.*, 1992, **29**, 155.
- 15 S. M. Stuczynski, Y. Kwon and M. L. Steigerwald, *J. Organomet. Chem.*, 1993, **449**, 167.
- 16 T. Kazuhiro and S. Yoshinori, *Bull. Chem. Soc. Jpn.*, 1992, **65**, 329.
- 17 T. Miyake, K. Hirakawa, M. Hanaya and J. Kawamura, *Eur. Pat. Appl.*, 475 355, 1992 (*Chem. Abstr.*, 1992, **116**, 255 160h).
- 18 M. L. Steigerwald, T. Siegrist and S. M. Stuczynski, *Inorg. Chem.*, 1991, **30**, 2256, 4940; S. M. Stuczynski, Y. Kwon and M. L. Steigerwald, *J. Organomet. Chem.*, 1993, **49**, 167.
- 19 D. C. Bradley, M. B. Hursthouse, C. W. Newing and A. J. Welch, *J. Chem. Soc., Chem. Commun.*, 1972, 567; B. Horvath, E. G. Horvath and J. Strutz, *Z. Anorg. Allg. Chem.*, 1979, **457**, 38.
- 20 B. Horvath, R. Möseler and E. G. Horvath, *Z. Anorg. Allg. Chem.*, 1979, **450**, 165.
- 21 R. A. Anderson, K. Faegri, J. C. Green, A. Haaland, M. F. Lappert, W. P. Leung and K. Rypdal, *Inorg. Chem.*, 1988, **27**, 1782.
- 22 H. Bürger and U. Wannagat, *Monatsh. Chem.*, 1963, **94**, 1007.

Received 10th April 1997; Paper 7/02460F